

SERIES 200 UL GROUND MOUNT SYSTEM

SnapNrack Residential PV Mounting Systems

The SnapNrack line of solar mounting systems is designed to reduce total installation costs. The system features technical innovations proven on more than 300+MW of solar projects to simplify installation and reduce costs.

Residential Ground Arrays Simplified

The SnapNrack Series 200 UL Ground Mount System is an efficient and visually appealing PV module installation system for small to medium size ground mount projects. Series 200 UL is designed to attach easily to a standard galvanized pipe structure using structural pipe fittings. Complete engineering tables are available for most site conditions with stamped engineering letters in all 50 states. Using a standard four-module assembly, the system is efficient and flexible while optimizing materials and minimizing system footprint. Industry leading installation times are achieved with unique snap-in fasteners.

- Assembles easily using snap-in bonding pipe clamps that feature channel nuts with integrated bonding pins
- Integrates with Schedule 40 or 80 galvanized 1.5" pipe
- Configures easily to desired tilt (0-45 degrees)
- Ultra-adjustable for precise alignment on any surface
- Rail channels provide excellent wire management

Patent Pending



Designing a Ground System in 3 Simple Steps:

- 1) Go to the online Series 200 Configuration Tool (configure.snapnrack.com)
- 2) Identify Site Parameters: Ground Pitch, Wind Speed, and Snow Load
- 3) Build array in the online Configuration Tool and automatically generate a Bill of Materials.
- 4) Place order with your distributor. Purchase material for a single project or order in bulk for additional savings



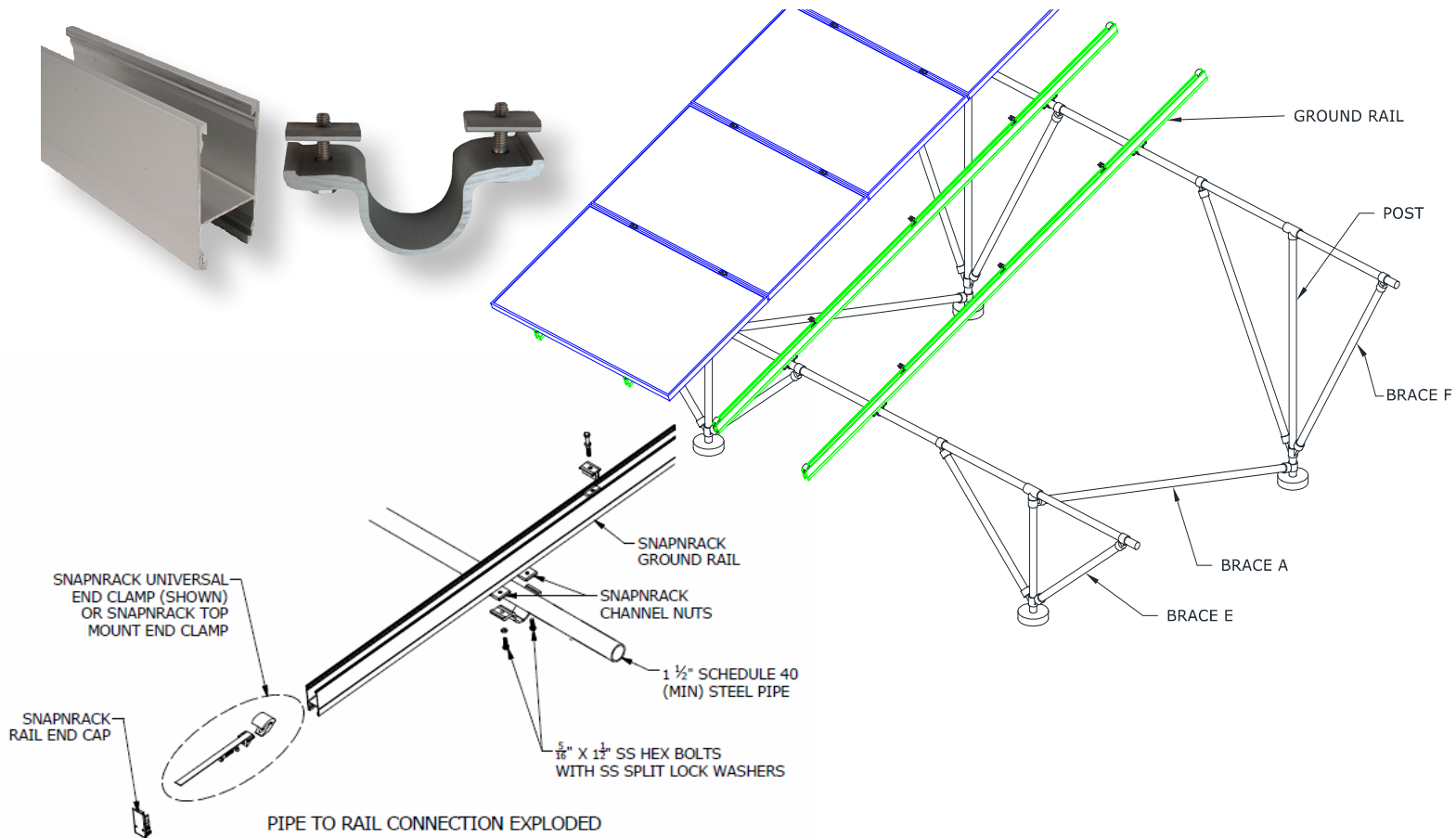

SnapNrack Series 200 UL Technical Data <small>Patent Pending</small>	
Tilt Angle	• 0-45 Degrees
Wind Speed	• Up to 120 MPH
Snow Loads	• Up 50 PSF
Foundation Options	• Concrete Encased Piers • Grade Beams • Driven Piles • Ballast Blocks
Materials	• 6000 Series Aluminum • Stainless Steel • Galvanized Steel
Material Finish	• Black & Clear Anodized Aluminum
Installation	• Quick & Efficient Mounting • Adjustable Hardware to Ensure Clean & Level Finish • Multiple Foundation Options
Grounding	• SnapNrack Grounding Lug (One Lug per individual row of modules)
Warranty	• 10 Year material and workmanship (download full details at snapnrack.com)

SnapNrack™
Solar Mounting Solutions

(877) 732-2860 www.SnapNrack.com

♻️ Printed on recycled paper using soy based inks.

© 2014 by SnapNrack PV Mounting System. All rights reserved.